



Performance evaluation test of Coriolis flow meters for hydrogen metering at high pressure

T. Morioka

National Metrology Institute of Japan, Central 3, 1-1-1 Umezono, Tsukuba, 305-8563, Japan
E-mail : tssj.morioka@aist.go.jp

Abstract

This paper describes the results of performance evaluation of Coriolis flow meters from various manufacturers in high-pressure hydrogen actual flow using a calibration system with critical flow Venturi nozzles as a reference. The calibration system consisting of five nozzles was developed to calibrate the flowmeters by high-pressure, high-flow-rate hydrogen gas. The performance evaluation test of the Coriolis flowmeters was conducted at maximum pressure of 70 MPa, gas temperature of 0 °C and -40 °C, and flow rate range from 0.5 kg/min to 3.0 kg/min. It was confirmed that the instrumental error of most of the DUTs tested in this paper was within $\pm 2.0\%$, although the instrumental error tended to be slightly larger at -40°C in the small flow rate range.

1. Introduction

In October 2020, Japan declared that it would aim to become “carbon neutral” by reducing greenhouse gas emissions to zero by 2050. Fuel cell vehicles (FCVs) are one of the most widely used hydrogen energy sources to reduce CO₂ emissions and solve energy problems as a countermeasure against global warming. At the end of FY2020, the number of FCVs owned is 5,170, and hydrogen stations (HRS: Hydrogen Refueling Stations) for refueling hydrogen, which is the fuel of FCVs, are operated at 161 locations, mainly in the four major metropolitan areas [1]. In the "Hydrogen/Fuel Cell Strategic Roadmap", FCVs are set to spread to 200,000 units in FY2025 and 800,000 units in FY2030, and the numerical target for HRS is to expand to 320 locations by FY2025 [2].

Flowmeter used to buy and sell hydrogen gas filled into FCV on-board tanks at HRS is transaction meter, so not only the reliability of the measurement values, but also reproducibility and long-term stability are strongly required. In order to carry out proper and fair hydrogen transactions in HRS for the purpose of consumer protection, technical standards for hydrogen measurement and flow standards are necessary.

Such background, Naka and the authors have developed a critical nozzle type flowmeter for high-pressure hydrogen that is traceable to national standards [3-5], and have evaluated the discharge coefficient characteristics of critical nozzles in high-pressure hydrogen. Furthermore, we have developed a calibration facility capable of

supplying 35MPa hydrogen, in order to calibrate flowmeters used as transaction meters [6].

Currently, hydrogen dispensers have a built-in flow meter that corresponds to the filling conditions for FCVs (maximum pressure: 87.5 MPa, maximum flow rate: 3.6 kg/min, precooling temperature: -40°C). The authors have also been researching and developing standards and calibration techniques for high-pressure hydrogen flow rates in response to such changes in filling conditions.

In this paper, a calibration system, whose capacity has been enhanced to conditions close to those currently used in hydrogen stations, is introduced. In addition, the results of performance evaluation test of the Coriolis flowmeters are shown at maximum pressure of 70 MPa, gas temperature of 0 °C and -40 °C, and flow rate range from 0.5 kg/min to 3.0 kg/min.

2. Calibration system

A calibration system used in this study was built-up by accumulating critical flow Venturi nozzle (CFVN) calibration from the national primary standard.

Figure 1 shows a traceability chain from the primary standard to the device under test (DUT).

The national primary standard of gas flow rate in the National Metrology Institute of Japan (NMIJ) is balance systems [7]. The DUTs calibrated with balance systems are CFVNs and are used as the working standards. The maximum hydrogen flow rate of the working standard is approximately 0.1 kg/min at a pressure of 0.7 MPa. Ten CFVNs with a throat diameter of about 2.4 mm are calibrated



by the working standards, and mounted on a multi-nozzle calibrator. The multi-nozzle calibrator can generate a maximum flow rate of about 1.0 kg/min at a pressure of 0.7 MPa, and is defined as a 2.1st standard.

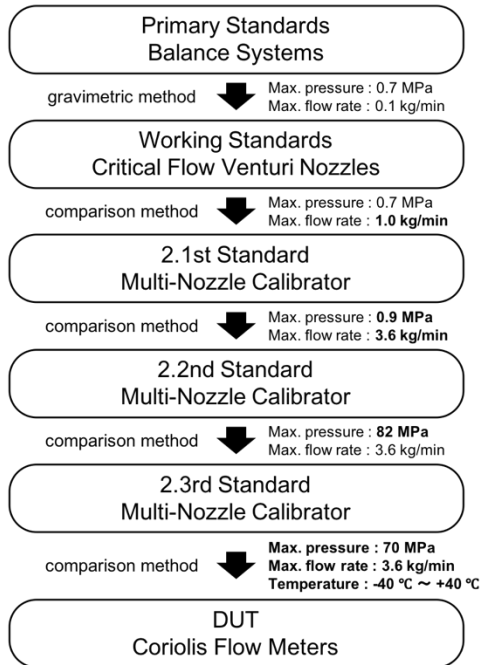

Figure 1: Traceability chain from the primary standard to the DUT.

Ten CFVNs with a throat diameter of about 3.6 mm mounted on a 2.2nd standard are calibrated by the 2.1st standard, and the generated flow rate range by the 2.2nd standard is expanded to a maximum flow rate of about 3.6 kg/min at a pressure of 0.9 MPa.

Furthermore, 5 CFVNs with different throat diameter mounted on a 2.3rd standard are calibrated by the 2.2nd standard. The upstream pressure of CFVNs of 2.3rd standard increases to 82 MPa. This makes it possible to calibrate the DUT under conditions similar to filling in HRS.

The DUT (Coriolis flowmeter) is calibrated by the 2.3rd standard at maximum pressure of 70 MPa and flow rate up to 3.6 kg/min. Previous study shown that the critical back pressure ratio of CFVN in high-pressure hydrogen is about 0.93 [5], however, the maximum calibration pressure for DUT is limited to 70 MPa due to pressure loss in pipes, joints and so on.

The calibration up to the 2.1st standard was performed at NMIJ, but the subsequent calibration with larger flow and higher pressure was performed at Hydrogen Energy Test and Research Center (HyTReC). HyTReC is the first institution in Japan to offer a full lineup of hydrogen testing

services, such as pressure cycle test, permeability test, filling test, leak test, creep test, burst test, expansion measurement test, and so on.

3. Performance evaluation procedure

The performance evaluation tests of Coriolis flowmeters were performed at the HyTReC. Table 1 shows the specification of hydrogen test facility. A normal (regular) pressure of the test facility is 110 MPa. Capability of hydrogen supplying facility is up to 2,400 m³/h. The test facility has an explosion resistant cover, the inside of which is purged with nitrogen gas and the leak of hydrogen is monitored by a hydrogen concentration sensor for safety purpose. The temperature inside the cover, that is, the temperature of the test environment, can be changed and controlled within the range of -40 °C to +85 °C. In this paper, the temperature of the test environment was set to around 0 °C. The test gas temperature can be cooled down to -40 °C by a heat exchanger using liquid nitrogen as a coolant so that the pre-cooling condition at the HRS can be simulated.

Table 1: Specification of hydrogen test facility in HyTReC [8].

| | |
|--|-------------------------|
| Storage gas | Hydrogen |
| Design pressure | 120 MPa |
| Normal pressure | 110 MPa |
| Max. flow rate | 2,400 m ³ /h |
| Temperature of test environment | -40 °C ~ +85 °C |
| Min. test gas temperature | -40 °C |

Figure 2 shows a diagram of performance evaluation test of Coriolis flow meters in high-pressure hydrogen actual flow using a calibration system. Hydrogen gas pressurized by the hydrogen supply facility is filled at 99 MPa into the storage tanks (300 L x 2) installed in the explosion resistant cover.

Test flow is generated by opening the pressure reducing valve (RV). The test flow rate can be arbitrarily determined by the combination of CFVN selection of the 2.3rd standard and pressure setting by RV. The flow rate range was from 0.5 kg/min to 3.0 kg/min. The temperature of the test gas flowing into the 2.3rd standard CFVN was set to around 0 °C by the temperature control unit and heat exchanger (HE1).

The test gas passing through the CFVN is set to the test temperature of the Coriolis flowmeter by another set of temperature control unit and heat exchanger (HE2). The test temperatures of the Coriolis flowmeter were set at 0 °C and -40 °C for the results presented in this paper. The upstream pressure of the Coriolis flowmeter is controlled by a flow control valve (FCV) installed its downstream, and its maximum pressure was 70 MPa.

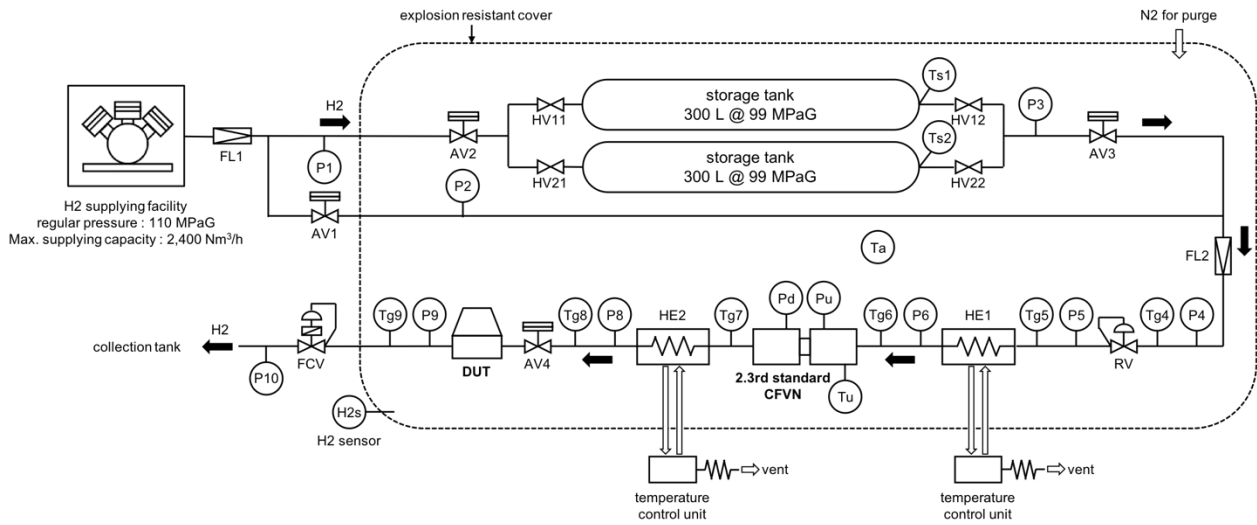

Figure 2: Diagram of performance evaluation test of Coriolis flow meters in high-pressure hydrogen actual flow using a calibration system.

The ejected hydrogen gas H₂ is sent to the recovery tank, pressurized again by the compressor, and sent to the hydrogen supply facility for reuse.

4. Results and discussion

The performance evaluation test of four Coriolis flowmeters was performed in this paper by using the above procedure. These flowmeters are indicated in the graph as DUT1 through DUT4. The test conditions of the Coriolis flowmeters were maximum pressure of 70 MPa, gas temperature of 0 °C and -40 °C, and flow rate range from 0.5 kg/min to 3.0 kg/min.

First, the measurement results of CFVN of the 2.3rd standard are shown, which are the criteria for the performance evaluation test.

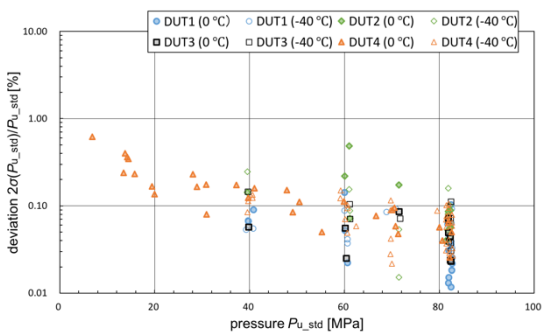

Figure 3: Pressure deviation at upstream of 2.3rd standard CFVN.

Figure 3 shows the deviation of upstream pressure of 2.3rd standard CFVN. Pressure range was from 5 MPa to 82 MPa. The results show that the upstream pressure was very stable over the pressure range with most deviations less than 0.3 %. Although the deviation became slightly larger when the pressure was low, it is considered

that there was no effect of the DUT or the test gas temperature of the DUT.

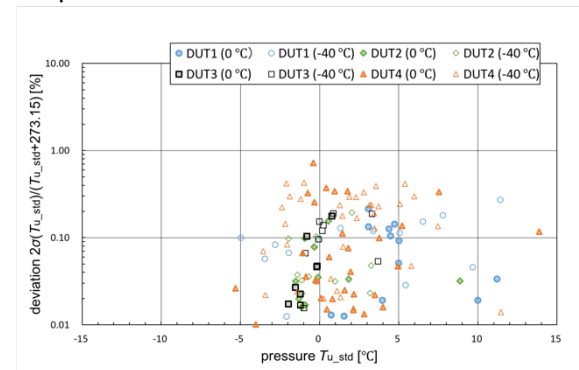

Figure 4: Temperature deviation at upstream of 2.3rd standard CFVN.

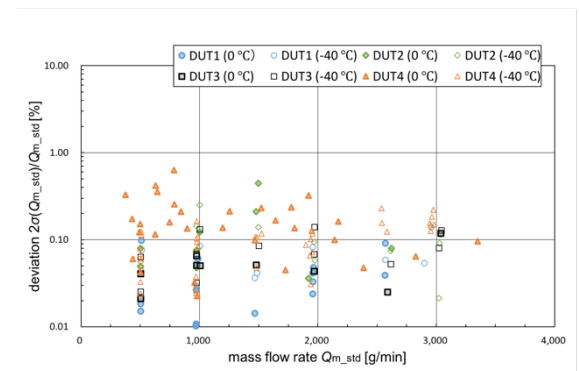

Figure 5: Deviation of flow rates generated by 2.3rd standard CFVN.

Figure 4 shows the deviation of upstream temperature of 2.3rd standard CFVN. As described above, the temperature of the test gas flowing into the 2.3rd standard CFVN was set to around 0 °C. As the test gas flow rate increases, temperature control becomes more difficult. As a result, the set temperature of the test gas varied. However, the



results show that the upstream temperature was very stable with most deviations less than 0.5 %.

Figure 5 shows the deviation of flow rates generated by 2.3rd standard CFVN. The flow rate range was from 0.5 kg/min to 3.0 kg/min in this paper. Although the deviation became slightly larger when the flow rate was small, most of the deviations are less than 0.3%.

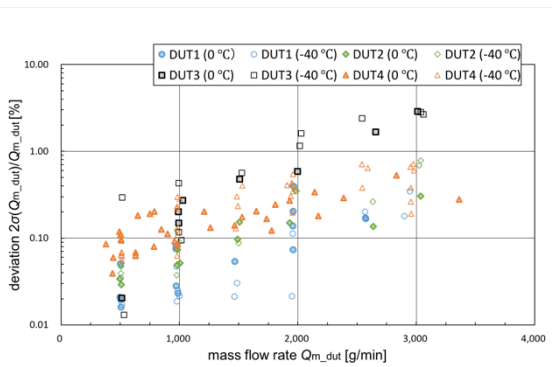

Figure 6: Deviation of flow rates indicated by Coriolis flow meters.

Figure 6 shows the deviation of flow rates indication of Coriolis flow meters, DUT1 through DUT4. The test gas temperature has little effect on the indications for each DUT. However, the deviation gradually increases as the test gas flow rate increases, and this trend is particularly noticeable in the results of DUT3.

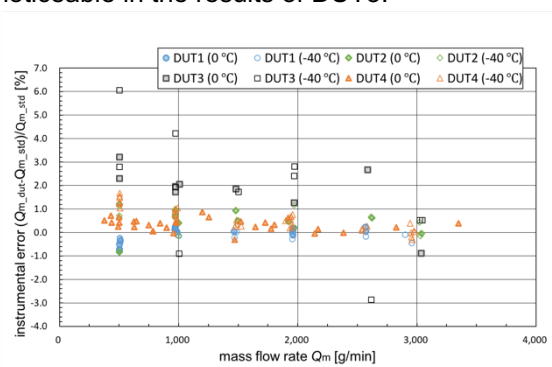

Figure 7: Instrumental errors between Coriolis flow meters and 2.3rd standard CFVN.

Figure 7 shows the instrumental errors between Coriolis flow meters and 2.3rd standard CFVN. It was confirmed that the instrumental error of the DUTs tested in this paper (except for DUT3) was within $\pm 2.0\%$ at the flow rate of 0.5 kg/min and $\pm 1.0\%$ at the flow rate more than it, although the instrumental error tended to be slightly larger at -40°C in the small flow rate range.

5. Conclusion

The performance evaluation test of Coriolis flow meters from various manufacturers in high-pressure hydrogen actual flow using a calibration

system with critical flow Venturi nozzles as a reference, were carried out under conditions of small deviation and high stability. Although differences in instrumental error between manufacturers were confirmed, no significant effects were observed in the low-temperature conditions that occur in the filling environment at HRSs.

Acknowledgement

This research was funded by the New Energy and Industrial Technology Development Organization (NEDO), under the “Research and Development Project for Hydrogen Utilization Technology / Research and Development on Low-Cost Devices and Systems for Fuel Cell Vehicles and Hydrogen Refueling Stations / Research and Development on Hydrogen Metering Management Methods at Hydrogen Refueling Stations”. In addition, I received a lot of cooperation from co-investigators in carrying out the research. I would like to express my gratitude by adding a note here.

References

- [1] Next Generation Vehicle Promotion Center, <http://www.cev-pc.or.jp> (July 15, 2022).
- [2] Hydrogen and Fuel Cell Strategy Council, Agency for Natural Resources and Energy, Ministry of Economy, Trade and Industry, “Hydrogen and Fuel Cell Strategy Roadmap”, 2019.
- [3] Nakao S, “Development of the critical nozzle type flow meter for 70 MPa dispenser and its evaluation test”, *FC Academic Forum, FC EXPO 2006*, 2006 (in Japanese).
- [4] Nakao S, “Development of the critical nozzle flow meter for high pressure hydrogen gas dispenser at a hydrogen gas station”, *in Proc. FLOMEKO 2005*, 2005.
- [5] Morioka T, Nakao S, and Ishibashi, M., “Characteristics of critical nozzle flow meter for measuring high-pressure hydrogen gas”, *J. Jpn. Soc. Mech. Eng. Ser. B*, **77**, 776, pp. 1088-1097, 2011 (in Japanese).
- [6] Morioka T, et al., “Development and evaluation of the calibration facility for high-pressure hydrogen gas flow meters”, *Flow Meas. Inst.*, **39**, pp.19-24, 2014.
- [7] Nakao S and Takamoto M, “Development of the calibration facility for small mass flow rates of gases and the sonic venturi nozzle transfer standard”, *JSME Intl. J. Ser. B*, **42**, 4, pp.667-673, 1999.
- [8] Hydrogen Energy Test and Research Center, <https://www.hytec.jp> (July 15, 2022).