

Introducing the SENIS SENCs1Dx: A Novel Current Sensor IC with Ultra-High Bandwidth and Exceptional Magnetic Resolution

Radivoje S. Popovic¹, Dragana Popovic Renella¹, Sasa Dimitrijevic¹, Bojan Milenkovic¹, Sasa Spasic¹

¹ SENIS Group, Switzerland, info@senis.swiss

Abstract – *This paper introduces a novel magnetic sensor IC for current sensing applications. The magnetic sensing function is based on the combination of the Hall effect devices for DC and low frequency fields, and an inductive coil for high frequency fields. The sensor IC incorporates a horizontal Hall device and a planar coil for the magnetic field perpendicular to the chip surface; and a vertical Hall device that can be combined with an external coil for the magnetic field parallel to the chip surface. The integrated signal processing electronics contains innovative circuits based on the switched capacitors, which combines the Hall and coil signals in a convenient, stable and reproducible way. The new sensor features the frequency bandwidth from DC to 1MHz and the equivalent magnetic field noise 40 μ Trms.*

I. INTRODUCTION

Electric current sensors [1] are crucial components in a range of industrial applications, including power generation, automotive, and consumer electronics industries. Accurate current measurements are essential for ensuring safety, efficiency, and performance in many apparatuses. One of the most important types of current sensors incorporates the magnetic sensor based on the Hall effect. The Hall elements allow for easy integration into a CMOS IC, making them compact, cost-effective, and energy-efficient. The basics of the Hall effect sensors are described, for example, in [2]-[3].

Practical implementations of Hall-based current sensors have limited bandwidths, typically from DC to less than 250 kHz [4]. The frequency limit comes about because of the use of the so-called spinning-current technique for cancelling offset of the Hall device [3]. To increase the bandwidth, a Hall element may be combined with an inductive coil, with the Hall sensor covering only the low-frequency sub-band [5]. In ref. [6] is described such a broadband magnetic sensor consisting of a hybrid combination of an integrated spinning-current, Hall sensor and a small coil on a printed-circuit board. The outputs of

the Hall and Coil signal paths are then summed up, which results in the frequency response of the hybrid sensor from DC to 3MHz, with the magnetic-equivalent noise 210 μ Trms.

In a magnetic sensor based on Hall-Coil combination, the respective signals pass through a first-order low-pass filter (further: LPF). The cut-off frequency of the LPF defines the cross-over frequency of the Hall and Coil signals, and also contributes to the effective gain of the Coil signal path. In order to get a flat frequency response of a magnetic sensor based on a Hall-Coil combination, the respective effective magnetic sensitivities of the two signal paths must be equal. Since the magnetic sensitivity of each of the two sensor signal paths depends on a few different parameters, it is not easy to ensure the stability and flatness of the frequency response of such a magnetic sensor over a large temperature range.

In this paper, we present a novel integrated magnetic sensor for current sensor applications, the SENIS® type SENCs1Dx, also known as ANYCS [7]. Similarly as the sensors described in refs. [5] and [6], this sensor is based on a combination of a Hall device and an inductive coil, and, therefore, features exceptionally high frequency bandwidth and low noise. Moreover, our new magnetic sensor has an innovative structure of the supporting electronic circuits [8], which allows for achieving a flat and stable frequency response over a large temperature range.

II. OPERATION PRINCIPLE OF THE MAGNETIC SENSOR SENCs1DX

The SENIS' magnetic field sensor SENCs1Dx is based on a combination of two different magnetic field sensor devices, a Hall device, and an inductive coil.

For an AC magnetic field, the output voltage of the Hall signal chain is approximatively given by

$$V_{hall}(t) = G_h * S_i * I_h * B_m * \cos(\omega t) \quad (1)$$

where G_h denotes the gain of the amplifiers in the Hall signal chain, S_i - the current-related magnetic sensitivity of the Hall device, I_h - the biasing current of the Hall element, B_m - the amplitude of the AC magnetic induction, and ω - the angular frequency of the B-field.

At low frequencies, the magnitude of the output signal of the Hall signal chain in Eq. (1) is independent of frequency; but, due to the spinning current technique, the frequency independence extends only to a few 10s of 100s kHz.

The voltage induced in the coil by a time-variable magnetic field is given by the Faraday's law. For an AC magnetic field, the output of the coil chain, the signal is given by

$$V_{ind}(t) = G_c * A * B_m * \omega * \sin(\omega t) \quad (2)$$

where G_c denotes the gain of the amplifiers in the coil signal chain, and A denotes the effective area of the coil. The sign of the gain G_c is chosen so that the inductive signal advances in phase for $\pi/2$ with respect to the Hall signal.

The amplitude of the signal of the coil chain (2) is proportional with its frequency. Since in the coil signal chain there is no switching operation, there is no such a severe bandwidth limitation at higher frequencies as that in the Hall signal chain; therefore, Eq. (2) is valid up to several MHz.

The frequency dependence of the coil signal (2) can be conveniently eliminated by passing this signal through a low-pass filter of the first order. At frequencies much higher than the cutoff frequency of this filter, the "gain" of the filter is inversely proportional with the frequency. Therefore, at higher frequencies, this filter cancels out the frequency dependence of the coil signal.

In SENCS1Dx, the amplified Hall signal, Eq. (1), and the amplified coil signal, Eq. (2), are added together, and then this common Hall+Coil signal passes through a first-order low-pass filter. Then, in the common signal, the Hall contribution dominates at DC and low frequencies up to the cutoff frequency of the low-pass filter (f_c); whereas the coil contribution dominates at frequencies higher than f_c . Figure 1 illustrates the frequency dependence of various signals in SENCS1Dx.

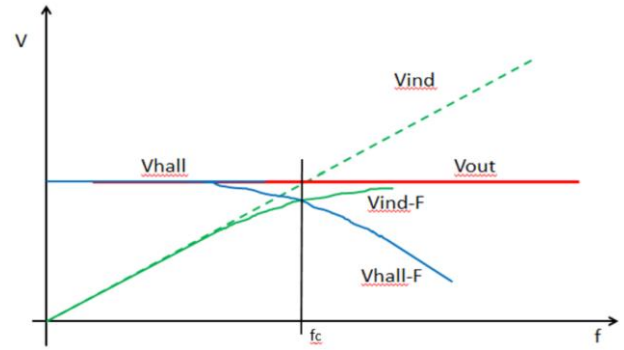

Fig. 1. The Frequency dependences of the amplitudes of the signals in the magnetic sensor based on a Hall-Coil combination. Notation: V_{hall} : non-filtered Hall voltage; V_{hall-F} : Hall voltage after low-pass filtering; V_{ind} : Non-filtered voltage of the inductive coil, V_{ind-F} : Voltage of the inductive coil after low-pass filtering; V_{out} : The sum of V_{hall} and V_{ind} after low-pass filtering; f_c : The cutoff frequency of the low-pass filter

The cutoff frequency of the low-pass filter (f_c) should be chosen so as to be equal with the frequency at which the amplitudes of the Hall signal and that of the inductive signals are equal. This frequency corresponds to the crossing point of the lines V_{hall} and V_{ind} in Fig. 1. The final result is that the amplitude of the common signal V_{out} is independent on the signal frequency. For details – see below the next section.

Therefore, the role of the low-pass filter is to provide frequency independence of the common signal; this low-pass filter does not limit at all the frequency bandwidth of the common signal. However, it does limit the bandwidth of the noise in the common signal, exactly as it limits the signal bandwidth of the Hall part of the common signal.

The noise bandwidth of the common Hall-Coil signal (f_c) might be at least 25 times smaller than the bandwidth of an only-Hall magnetic sensor (f_{ch}); therefore, the noise of a Hall-Coil sensor could be at least 5 times lower than that of an only-Hall magnetic sensor.

III. THE RELATIONSHIP AMONG THE PARAMETERS OF THE HALL CHAIN, COIL CHAIN, AND THE LOW PASS FILTER

The voltages V_{hall} (1) and V_{ind} (2) can be represented in the complex forms by the phasors

$$pV_h = G_h * S_i * I_h * B_m \quad (3)$$

$$pV_i = j * \omega * G_c * A * B_m \quad (4)$$

Let the transfer characteristic of the LPF be given by

$$(V_{out}/V_{in}) = G_f / (1 + j * \omega * T_f) \quad (5)$$

where G_f denotes its voltage gain and T_f is the time constant of the filter. Then, if we apply as the input voltage of the filter the sum of the voltages (3) and (4), the phasor of the output voltage of the filter will be

$$pV_{out} = G_f * S_i * I_h * B_m * [(1 + j * \omega * G_c * A / (G_h * S_i * I_h)) / (1 + j * \omega * T_f)] \quad (6)$$

In this equation, the terms $[(1 + j * \omega * G_c * A / (G_h * S_i * I_h)) / (1 + j * \omega * T_f)]$ will cancel out if we chose the parameters of the Hall chain, coil chain, and of the low-pass filter so that the following equation is fulfilled:

$$T_f = G_c * A / (G_h * S_i * I_h) \quad (7)$$

or, since the cutoff frequency is related to the time constant, $f_c = 1 / (2 \pi * T_f)$, the condition (7) can be expressed as

$$f_c = G_h * S_i * I_h / (2 * \pi * A * G_c) \quad (8)$$

Then Eq. (6) reduces to

$$pV_{out} = G_f * S_i * I_h * B_m \quad (9)$$

This means that, if Equation (8) is fulfilled, the output voltage of the filter V_{out} will be independent of frequency, as illustrated in Fig. 1, and it will be in phase with the magnetic field signal.

In order to enable the fulfillment of Eq. (8) in spite of the fabrication tolerances, the gains G_h and G_c of the SENCS1Dx are made adjustable. During the calibration process of the SENCS1Dx, these two gains are adjusted so as to give both desired magnetic sensitivity and flat frequency response of the magnetic sensor. However, in Eq. (8), each of the parameters f_c , S_i , and I_h , might have different and non-linear temperature dependences, which would make difficult keeping Eq. (8) valied over a large temperature range. We solved this difficulty by implementing the corresponding supporting circuits in the form of the switched capacitor circuits that make I_h and f_c proportional to the same stable clock frequency [8].

IV. STRUCTURE OF THE SENCS1DX

The SENCS1Dx current sensor incorporates integrated Hall devices, coils, analog signal processing channels, control logic, and ADC. Figure 2 depicts the sensor chip's block diagram, including the horizontal and vertical Hall elements (X) and their corresponding coils (H and V). While the horizontal coil is integrated into the chip, the vertical coil is separate and can be added off-chip.

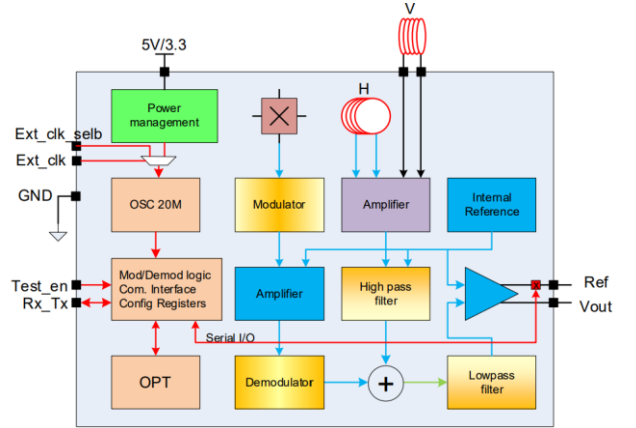

Fig. 2. Block diagram of SENCS1Dx

The sensor architecture employs both SENIS horizontal and vertical Hall elements, which offer the industry's most exceptional magnetic resolution [9]. With this dual Hall element configuration, the sensor can sense magnetic fields along any desired axis (perpendicular to, or parallel with the chip surface), thereby earning the name ANYCS.

V. EXPERIMENTAL RESULTS

The SENCS1Dx chips are fabricated in a high-voltage 0.18 μ m CMOS technology.

Fig. 3 shows the layout of the chip.

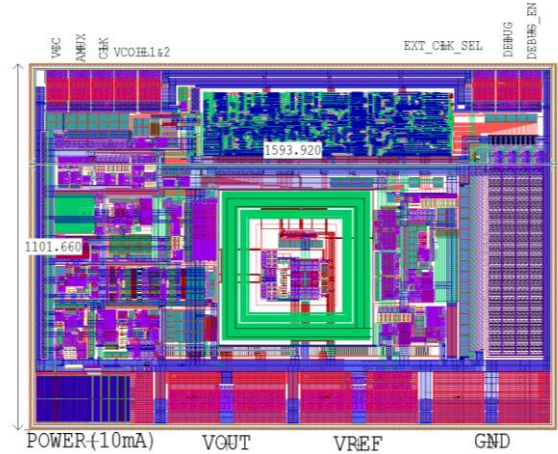

Fig. 3. The layout of the SENCS1Dx. The big square (green) in the middle is the planar coil. The horizontal and vertical Hall elements are situated in the coil.

In Table 1 we summarize the main test conditions and test results of the SENCS1Dx.

Fig. 4 shows the relative variation of the magnetic sensitivity of the SENCS1Dx as a function of the frequency of the magnetic field. The curve is reasonably

flat over the whole sensor bandwidth, from DC to 1MHz.

40 μ Trms.

Table 1. Test conditions and performance parameters

Parameter	Symbol	Value	Unit
Power supply Voltage	VCC	5	V
Current @VCC	IVCC	9.8	mA
Hall biasing current	Ibias	0.96	mA
Hall Low Pass filter	LP	2	kHz, @Fclk=8MHz
Coil High pass filter	HP	100	Hz
Oscillator	Fclk	8	MHz
Magnetic field range	FS	5	mT
Magnetic sensitivity	S	210	V/T
Output voltage noise	Vn	9	mVrms
Eq. magnetic noise	Bn	40	μ Trms

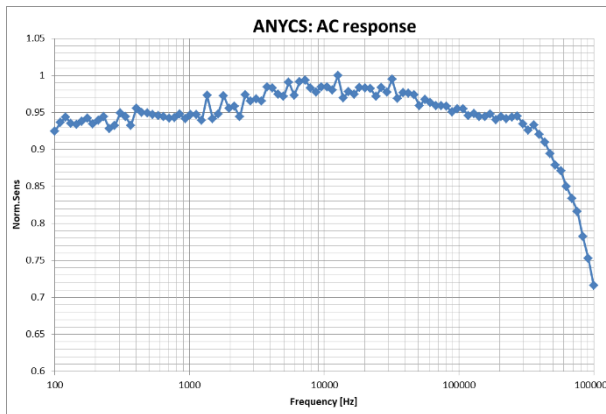

Fig. 4. Frequency response

Fig. 5 illustrates the noise spectral density over the sensor frequency bandwidth. As expected, most of the noise appears at the frequencies below the cutoff frequency of the low-pass filter.

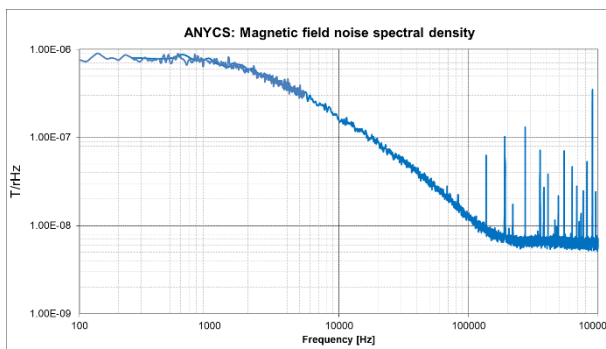

Fig. 5. The equivalent magnetic field noise spectral density

In a separate measurement, we made a histogram of the noise voltage over the whole sensor bandwidth (DC to 1MHz), which revealed the standard deviation of 9mV. This corresponds to the equivalent input magnetic field noise of

VI. CONCLUSIONS AND OUTLOOK

Based on the known concept of the combination Hall-Coil [5], [6], and new ideas [7], [8] that support its implementation, we developed the new integrated magnetic sensor, the SENIS® SENCSDx, also known as ANYCS, with extraordinary features: Magnetic sensitivity direction either perpendicular to, or parallel with the chip surface, frequency bandwidth from DC to 1MHz, equivalent magnetic field noise 40 μ T, and high stability against temperature changes. The SENCSDx is a fully integrated sensor for the magnetic field perpendicular to the chip surface, whereas for the magnetic field parallel with the chip surface, it should be combined with a suitable external coil.

With its unique performance, the SENIS ANYCS sensor is poised to revolutionize electric current measurement solutions. Its first applications are expected in electric bicycles, AC magnetic field monitoring for green cars stations, and power electronics, among others. High-accuracy measurement with SENIS sensors is moving the limits of what is currently possible and available on the market, leading to further advances in sensor technology and applications.

REFERENCES

- [1] P. Ripka, "Electric current sensors: a review", Measurement Science Technology, 2010
- [2] R. S. Popovic: "Hall-effect devices", Journal for Sensors and Actuators, Volume 17, Issues 1-3, 1989
- [3] R. S. Popovic "Hall Effect Devices", 2nd Edition CRC Press Taylor & Francis Group, LLC 2003, ISBN: 978-1-4200-3422-6
- [4] MLX91208, 250 kHz IMC-Hall® current sensor IC with enhanced thermal and lifetime stability, 2022
- [5] N. Karrer, P. Hofer-Noser, "Device with wide passband for measuring electric current intensity in a conductor", Patent US 6,366,076 B1, 2002
- [6] J. Jiang, K.A.A. Makinwa, "Multipath Wide-Bandwidth CMOS Magnetic Sensors", IEEE J. Solid-State Circuits. (2016) 1–12. doi:10.1109/JSSC.2016.2619711
- [7] SENIS® ANYCS current sensor IC with high bandwidth from DC-1MHz, www.senis.swiss, 2023
- [8] Patent 2022110921071100DE, "Magnetfeldsensormit einem temperaturgangskompensierten Ausgangssignal sowie Verfahren für die Temperaturgangkompensation eines Ausgangssignals eines Magnetfeldsensormit", 2022
- [9] Patent EP14176835.8, "Vertical Hall Device", 2016